

型式 **SMA**
TYPE

(連座標準型直線軸承)

GHT 直線軸承系列

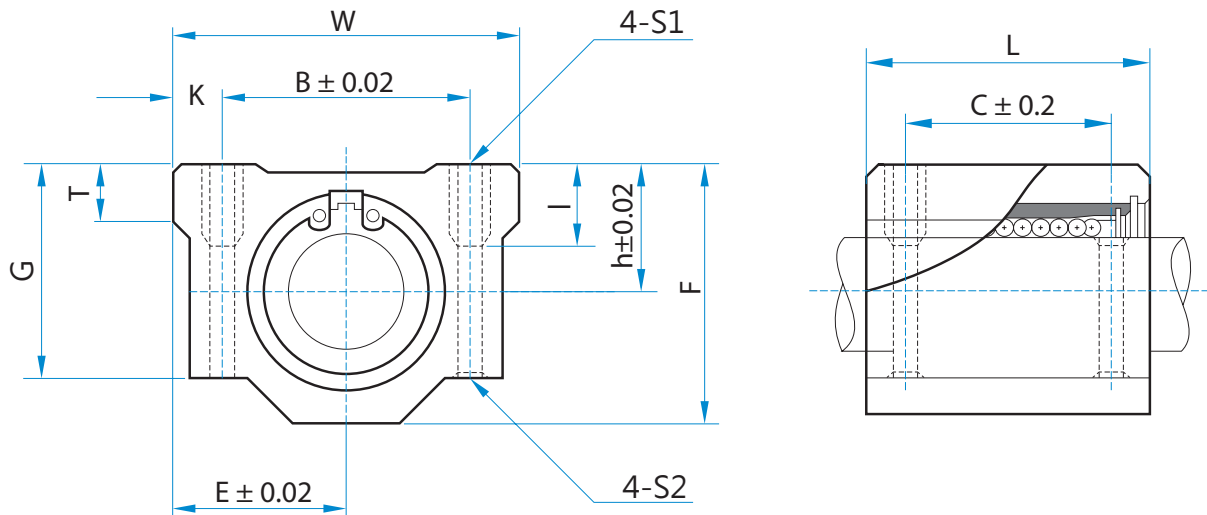

型號 MODEL NO	軸徑 SHAFT DIAMETER	主要尺寸 MAIN DIMENSIONS							安裝尺寸 MOUNTING DIMENSIONS						動荷重 C(kgf)	靜荷重 Co(kgf)	重量 WEIGHT (g)
		h	E	W	L	F	G	T	B	C	K	S1	S2	I			
SMA08	8	11	17	34	30	22	18	6	24	18	5	M4	3.4	8	28	40	52
SMA10	10	13	20	40	35	26	21	8	28	21	6	M5	4.3	12	38	56	92
SMA12	12	15	21	42	36	28	24	8	30.5	26	5.75	M5	4.3	12	52	80	102
SMA13	13	15	22	44	39	30	24.5	8	33	26	5.5	M5	4.3	12	52	80	120
SMA16	16	19	25	50	44	38.5	32.5	9	36	34	7	M5	4.3	12	79	120	200
SMA20	20	21	27	54	50	41	35	11	40	40	7	M6	5.2	12	90	140	255
SMA25	25	26	38	76	67	51.5	42	12	54	50	11	M8	7	18	100	160	600
SMA30	30	30	39	78	72	59.5	49	15	58	58	10	M8	7	18	160	280	735
SMA35	35	34	45	90	80	68	54	18	70	60	10	M8	7	18	170	320	1100
SMA40	40	40	51	102	90	78	62	20	80	60	11	M10	8.7	25	220	410	1590
SMA50	50	50	61	122	110	102	80	25	100	80	11	M10	8.7	25	390	810	3340
SMA60	60	60	66	132	122	114	94	30	108	90	12	M12	10.7	25	482	1020	4270

型式 TYPE **SMA-L**

(標準加長型直線軸承)

GHT 直線軸承系列

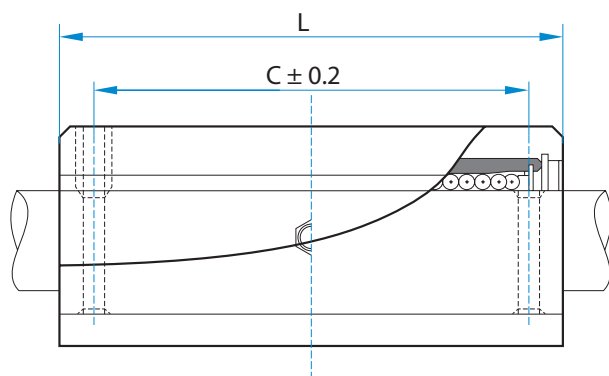
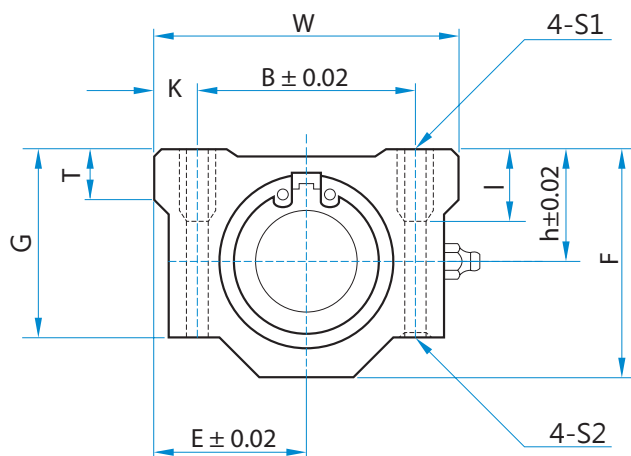
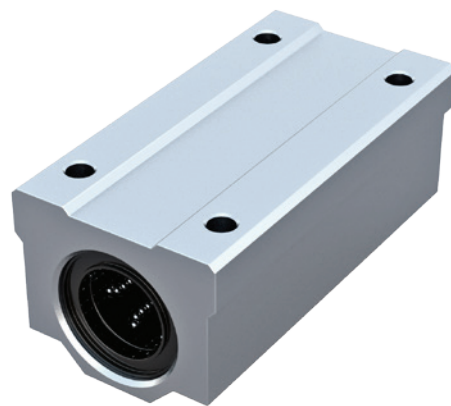

型號 MODEL NO	軸徑 SHAFT DIAMETER	主要尺寸 MAIN DIMENSIONS							安裝尺寸 MOUNTING DIMENSIONS					動荷重 C(kgf)	靜荷重 Co(kgf)	重量 WEIGHT (g)	
		h	E	W	L	F	G	T	B	C	K	S1	S2				I
SMA08-L	8	11	17	34	58	22	18	6	24	42	5	M4	3.4	8	44	80	102
SMA10-L	10	13	20	40	68	26	21	8	28	46	6	M5	4.3	12	60	112	180
SMA12-L	12	15	21	42	70	28	24	8	30.5	50	5.75	M5	4.3	12	83	160	205
SMA13-L	13	15	22	44	75	30	24.5	8	33	50	5.5	M5	4.3	12	83	160	240
SMA16-L	16	19	25	50	85	38.5	32.5	9	36	60	7	M5	4.3	12	125	240	400
SMA20-L	20	21	27	54	96	41	35	11	40	70	7	M6	5.2	12	144	280	570
SMA25-L	25	26	38	76	130	51.5	42	12	54	100	11	M8	7	18	164	320	1200
SMA30-L	30	30	39	78	140	59.5	49	15	58	110	10	M8	7	18	250	560	1480
SMA35-L	35	34	45	90	155	68	54	18	70	120	10	M8	7	18	270	640	2200
SMA40-L	40	40	51	102	175	78	62	20	80	140	11	M10	8.7	25	350	820	3200
SMA50-L	50	50	61	122	215	102	80	25	100	160	11	M10	8.7	25	620	1620	6700
SMA60-L	60	60	66	132	240	114	94	30	108	180	12	M12	10.7	25	770	2040	8560

型式
TYPE **SMB**

(自潤標準型直線軸承)

GHT 直線軸承系列

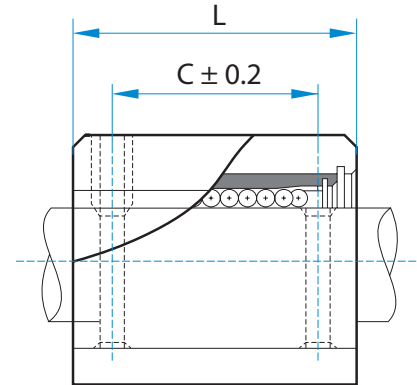
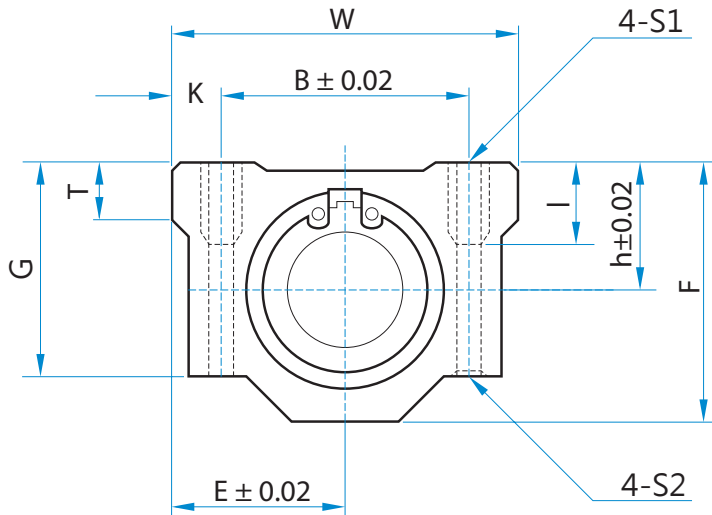
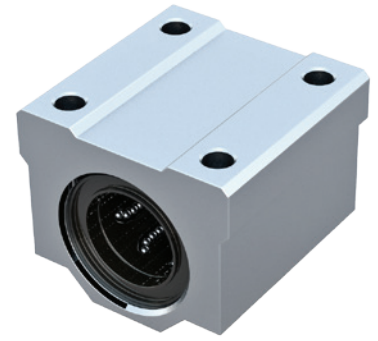

型號 MODEL NO	軸徑 SHAFT DIAMETER	主要尺寸 MAIN DIMENSIONS							安裝尺寸 MOUNTING DIMENSIONS						動荷重 C(kgf)	最大速度 m/min		重量 WEIGHT (g)
		h	E	W	L	F	G	T	B	C	K	S1	S2	I		無給油	給油	
SMB08	8	11	17	34	30	22	18	6	24	18	5	M4	3.4	8	202	40	120	45
SMB10	10	13	20	40	35	26	21	8	28	21	6	M5	4.3	12	305	40	120	78
SMB12	12	15	21	42	36	28	24	8	30.5	26	5.75	M5	4.3	12	378	40	120	89
SMB16	16	19	25	50	44	38.5	32.5	9	36	34	7	M5	4.3	12	622	40	120	170
SMB20	20	21	27	54	50	41	35	11	40	40	7	M6	5.2	12	882	40	120	220
SMB25	25	26	38	76	67	51.5	42	12	54	50	11	M8	7	18	1549	40	120	500
SMB30	30	30	39	78	72	59.5	49	15	58	58	10	M8	7	18	2016	40	120	635
SMB35	35	34	45	90	80	68	54	18	70	60	10	M8	7	18	2573	40	120	925
SMB40	40	40	51	102	90	78	62	20	80	60	11	M10	8.7	25	3360	40	120	1340
SMB50	50	50	61	122	110	102	80	25	100	80	11	M10	8.7	25	5250	40	120	2590
SMB60	60	60	66	132	122	114	94	30	108	90	12	M12	10.7	25	6930	40	120	3430

型式
TYPE **SMB-L**

(自潤加長型直線軸承)

GHT 直線軸承系列

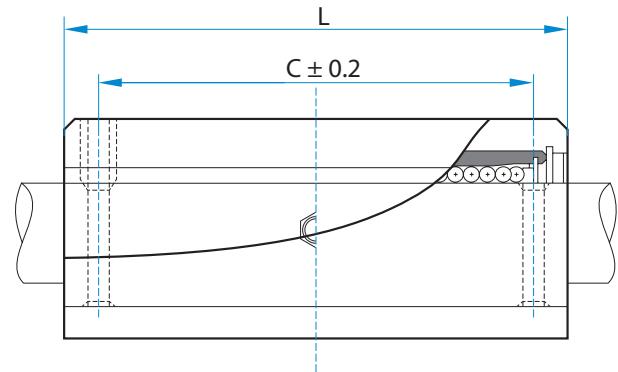
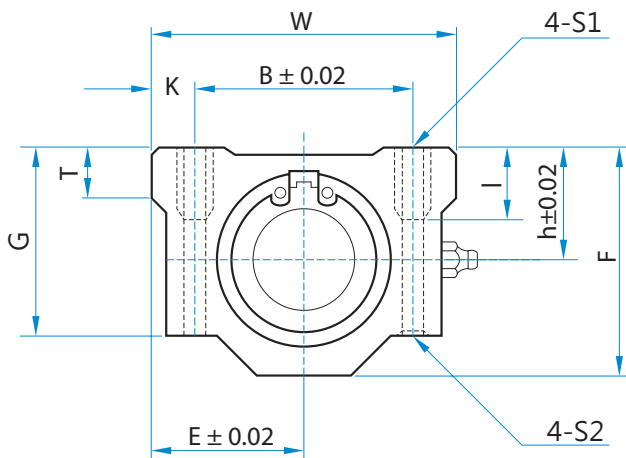
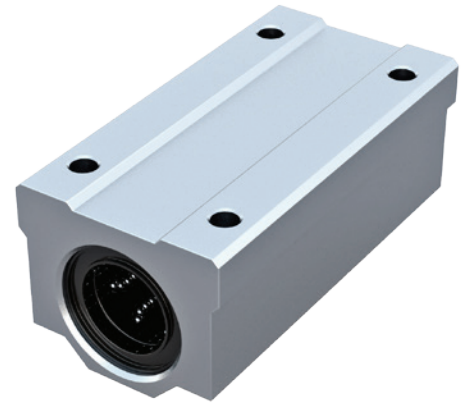

型號 MODEL NO	軸徑 SHAFT DIAMETER	主要尺寸 MAIN DIMENSIONS							安裝尺寸 MOUNTING DIMENSIONS					動荷重 C(kgf)	最大速度 m/min		重量 WEIGHT (g)	
		h	E	W	L	F	G	T	B	C	K	S1	S2		I	無給油		給油
SMB08-L	8	11	17	34	58	22	18	6	24	42	5	M4	3.4	8	400	40	120	90
SMB10-L	10	13	20	40	68	26	21	8	28	46	6	M5	4.3	12	700	40	120	150
SMB12-L	12	15	21	42	70	28	24	8	30.5	50	5.75	M5	4.3	12	750	40	120	180
SMB16-L	16	19	25	50	85	38.5	32.5	9	36	60	7	M5	4.3	12	1200	40	120	340
SMB20-L	20	21	27	54	96	41	35	11	40	70	7	M6	5.2	12	1700	40	120	500
SMB25-L	25	26	38	76	130	51.5	42	12	54	100	11	M8	7	18	3000	40	120	1000
SMB30-L	30	30	39	78	140	59.5	49	15	58	110	10	M8	7	18	4000	40	120	1280
SMB35-L	35	34	45	90	155	68	54	18	70	120	10	M8	7	18	5100	40	120	1850
SMB40-L	40	40	51	102	175	78	62	20	80	140	11	M10	8.7	25	6700	40	120	2700
SMB50-L	50	50	61	122	215	102	80	25	100	160	11	M10	8.7	25	10500	40	120	5200
SMB60-L	60	60	66	132	240	114	94	30	108	180	12	M12	10.7	25	13800	40	120	6900

型式 **SME**
TYPE

(開口型直線軸承)

GHT 直線軸承系列

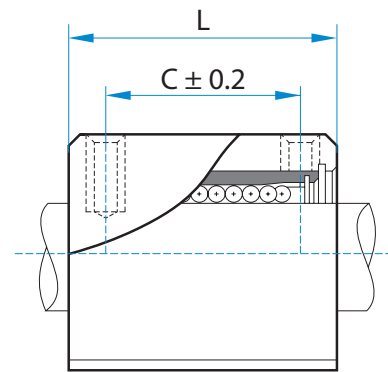
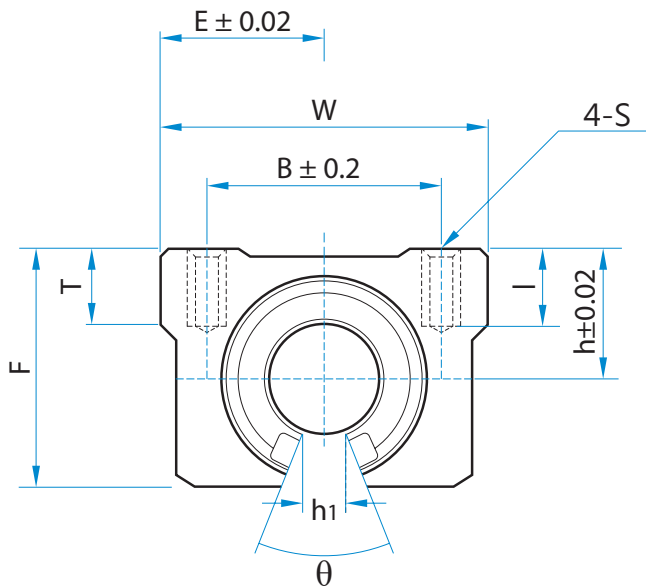
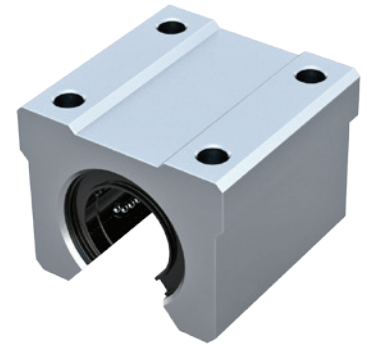

型號 MODEL NO	軸徑 SHAFT DIAMETER	主要尺寸 MAIN DIMENSIONS								安裝尺寸 MOUNTING DIMENSIONS				動荷重 C(kgf)	靜荷重 Co(kgf)	重量 WEIGHT (g)
		H	E	W	L	F	T	h1	θ	B	C	S	I			
SME10	10	15	18	36	32	24	7	6	80°	25	20	M5	10	38	56	92
SME12	12	17	20	40	39	27.6	8	8.5	80°	28	26	M5	10	52	80	102
SME13	13	17	20	40	39	27.6	8	8.5	80°	28	26	M5	10	52	80	120
SME16	16	20	22.5	45	45	33	9	10	80°	32	30	M5	12	79	120	200
SME20	20	23	24	48	50	39	11	10	60°	35	35	M6	12	90	140	255
SME25	25	27	30	60	65	47	14	11.5	50°	40	40	M8	12	100	160	600
SME30	30	33	35	70	70	56	15	14	50°	50	50	M8	18	160	280	735
SME35	35	37	40	80	80	63	18	16	50°	55	55	M8	18	170	320	1100
SME40	40	42	45	90	90	72	20	19	50°	65	65	M10	20	220	410	1590
SME50	50	53	60	120	110	92	25	23	50°	94	80	M10	20	390	810	3340

GHT 台灣勁亨軸承有限公司
東莞勁前機電有限公司

台灣省新北市蘆洲區和平路114巷2號1樓
TEL: +886-2-2281 1666 FAX: +886-2-2281 0777

www.ghtght.com.tw

TAIWAN GENERAL HENRY BEARING CO.,LTD.

型式
TYPE **SME-L**

(開口加長型直線軸承)

GHT 直線軸承系列

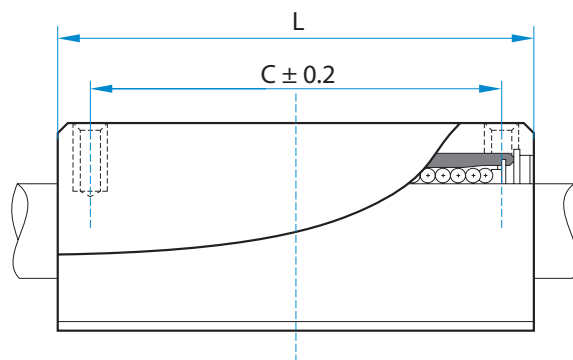
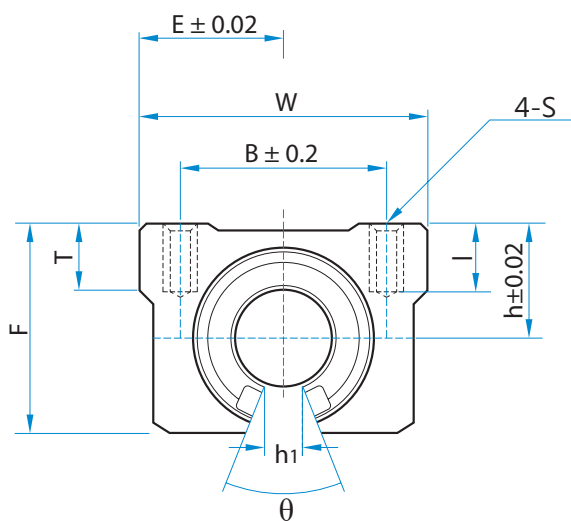
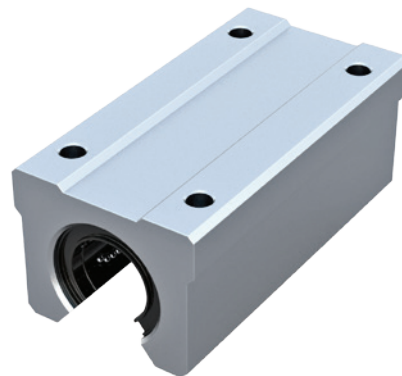

型號 MODEL NO	軸徑 SHAFT DIAMETER	主要尺寸 MAIN DIMENSIONS								安裝尺寸 MOUNTING DIMENSIONS				動荷重 C(kgf)	靜荷重 Co(kgf)	重量 WEIGHT (g)
		H	E	W	L	F	T	h1	θ	B	C	S	I			
SME16-L	16	20	22.5	45	82	33	9	10	80°	32	68	M5	12	125	230	300
SME20-L	20	23	24	48	92	39	11	10	60°	35	70	M6	12	180	280	400
SME25-L	25	27	30	60	124	47	14	11.5	50°	40	100	M6	12	200	320	900
SME30-L	30	33	35	70	134	56	15	14	50°	50	115	M8	18	320	560	1260
SME35-L	35	37	40	80	150	63	18	16	50°	55	126	M8	18	350	630	1180
SME40-L	40	42	45	90	175	72	20	19	50°	65	140	M10	20	-	-	-

型式
TYPE **TBR**

(連座法蘭型直線軸承)

GHT 直線軸承系列

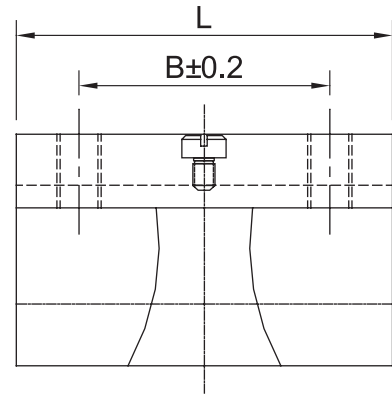
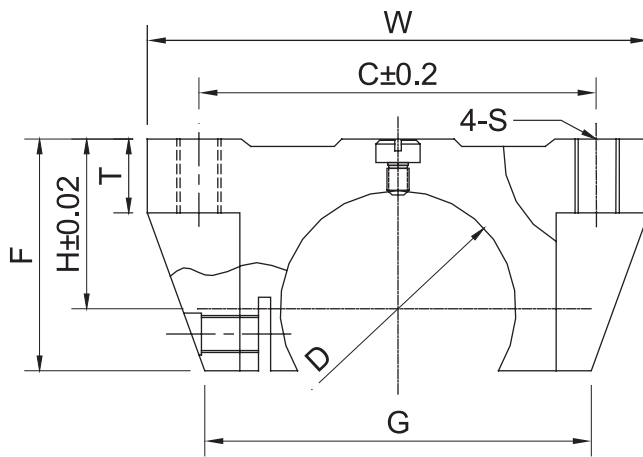
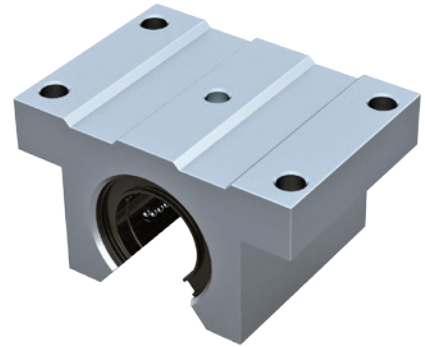

型號 MODEL NO	主要尺寸 MAIN DIMENSIONS							安裝尺寸 MOUNTING DIMENSIONS				動荷重 C(kgf)	靜荷重 Co(kgf)	重量 WEIGHT (Kg)
	D	H	E	T	F	G	W	B	C	L	S			
TBR16	28	17.86	31	8	27	48	62	30	50	42	M5	-	-	0.18
TBR20	32	20.99	34	10	31.4	52.4	68	37	54	51	M6	-	-	0.30
TBR25	40	28.00	41	12	41	61	82	50	65	65	M8	-	-	0.60
TBR30	45	33.48	45.5	12	48	65	91	60	75	75	M8	-	-	0.90

GHT 台灣勁亨軸承有限公司
東莞勁前機電有限公司

台灣省新北市蘆洲區和平路114巷2號1樓
TEL: +886-2-2281 1666 FAX: +886-2-2281 0777

www.ghtght.com.tw
TAIWAN GENERAL HENRY BEARING CO.,LTD.